

CLOSET ORGANIZER SYSTEM

by

ACME
Exclusiv®

14206-128 Avenue NW, Edmonton, Alberta T5L 3H5
Tel.: **780.452.6941** • Fax: 780.452.2463
acmeexclusiv@gmail.com • acmeexclusivclosetdoors.com



Closet Organizer System

Change your plans and double your usable closet space without changing the size of your closet. Ideal for walk-in closets as well.

The Ultimate Closet Space Maximizer!

The homes and offices across this country with enough closet storage space are few and far between. ACME's Closet Organizer is an easy-to-design, modular component system which allows up to twice the space utilization in closets. You can specify added hanger space, added shelf space in a system that is completely flexible and adaptable to any size of closet.

The ACME Closet Organizer System boasts sturdy construction so it is at home, even in demanding commercial applications. It is prefinished in white.

Used separate from the system, the hanger bar and shelf combination provides a very high quality substitute for conventional installations. As well, the regular closet shelf component is the perfect answer for storage areas such as pantries and linen closets. **Maximize available closet space By Design!**

General Specifications:

820 Shelf System: The 820 Shelf Unit is 16" (40.6 cm) deep, 84" (213 cm) high and is 16 7/16" (41.8 cm) wide. Prefinished vertical supports are 5/8" (15.9 mm) thick.

4820 Closet Shelf: The 4820 Shelf is assembled into plastic moulded end brackets with prefinished roll-formed steel shelf edges. Shelf inserts are 5/32" to 3/16" (4.5 mm) thick prefinished panels. Use the ACME 4823 centre brace for any shelf over 4' (1.22 m) in length, and one for each additional 4' (1.22 m) length. Available in 12" (30.5 cm) and 16" (40.6 cm) depths and in lengths up to 12'0 (3.66 m).

4820 Closet Shelf and Hanger Bar: The Closet Shelf and Hanger Bar combination features shelf specifications identical to the 4820 above. The Hanger Bar is made of prefinished roll-formed steel and is capped with a high impact plastic shield so that hangers glide with fingertip touch.



4820 Closet Shelf & Hanger Bar System

4820 - The Ultimate Alternative

Gone are the days when fine homes and offices must be saddled with unfinished, unattractive closet shelves and hanger rods.

The ACME 4820 Closet Shelf System is available with or without hanger bar, in 12" (305 mm) or 16" (406 mm) depths, and in any length. The moulded plastic end brackets, hardboard shelf panels, steel shelf edges, and hanger bar components are all prefinished in white. A tough clear end cap protects the bar from scratches and facilitates sliding of hangers.

The 4820 System eliminates the need for wood cleats to support the shelf and ACME's 4820 Wall Anchor holds the System solidly in hollow-wall applications.

Attractive Closet Rods and Shelving By Design!

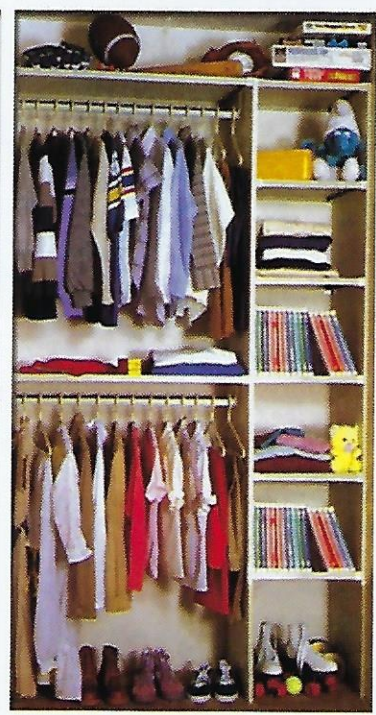
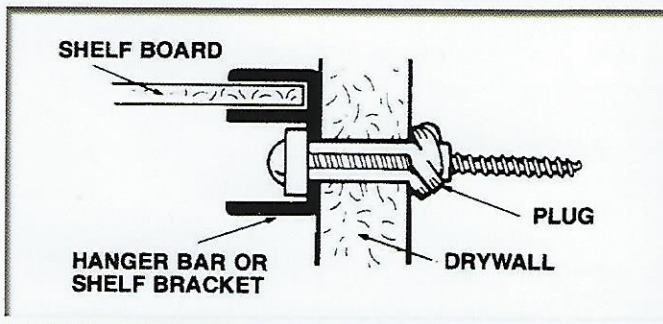
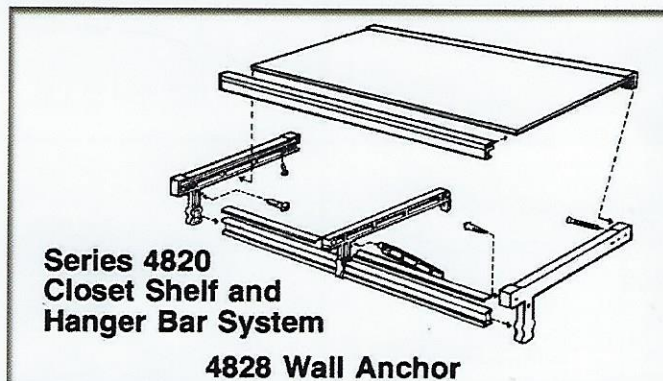

14206-128 Avenue NW, Edmonton, Alberta T5L 3H5

Tel.: **780.452.6941** • Fax: 780.452.2463

acmeexclusiv@gmail.com • **acmeexclusivclosetdoors.com**



SERIES 800 / 4820

Closet Organizer and Closet Shelf and Hanger Bar System

SYSTEM SPECIFICATIONS

820 Shelf System: The 820 Shelf Unit shall be 16" (40.6cm) deep, 84" (213cm) high and 16 7/16" (41.8cm) wide. Prefinished vertical supports shall be 5/8" (15.9cm) thick.

4820 Closet Shelf: The 4820 Shelf shall be assembled into plastic moulded end brackets with prefinished roll-formed steel shelf edges. Shelf inserts shall be 5/32" to 3/16" (4.5mm) thick prefinished panels. Use the Acme 4823 centre brace for any shelf over 4' (1.22M) in length and one for each additional 4' (1.22M) length. Available in 12" (30.5cm) and 16" (40.6cm) depths and in lengths up to 12'0" (3.66M).

4820 Closet Shelf and Hanger Bar: The Closet Shelf and Hanger Bar combination shall feature Shelf Specifications identical to the 4820 above. The Hanger Bar shall be made of prefinished roll-formed steel and shall be capped with a high impact plastic shield so that hangers will glide with fingertip touch.

SERIES 820 CLOSET SHELVING SYSTEM

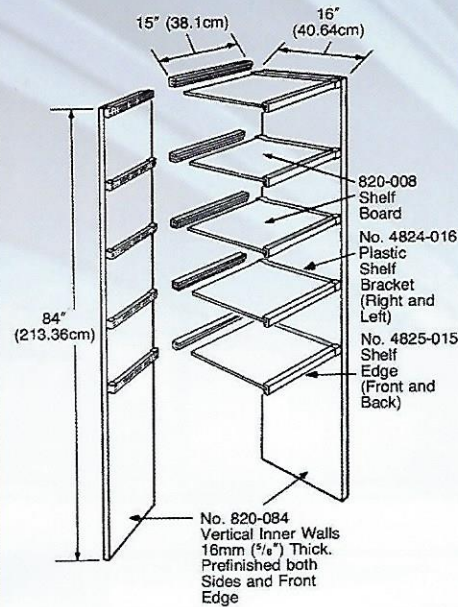

SERIES 4820 12" (30.48cm) CLOSET SHELF AND HANGER BAR

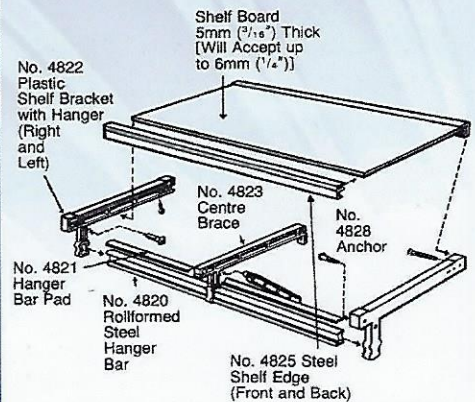

NOTE: Centre brace required for installations over 1.22m (4') in length and one for each additional 1.22m (4').

ALSO AVAILABLE 16" (40.64cm) Depth

CLOSET CONFIGURATION:

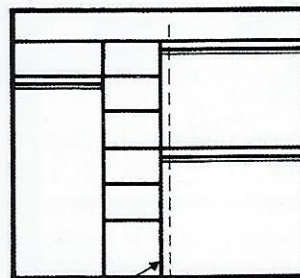
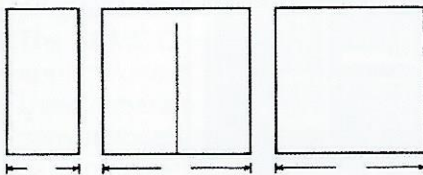

SERIES 4820 12" (30.48cm) CLOSET SHELF

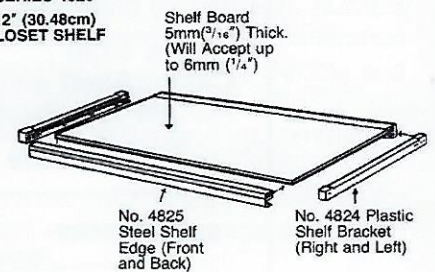

BOARD RECOMMENDATION:

For best performance use board with both sides prefinished with a print, paper or vinyl finish. Once installed in the system, the performance characteristics of the board must be such that the panels will not only remain flat, but offer substantial resistance to twisting and warpage when exposed to extreme variations of humidity.

Approval and/or proof of performance of any panel used must be obtained directly from the manufacturer or source of supply for the specific product.

Acmetrack cannot assume responsibility for board performance, but will assist in evaluating various products.

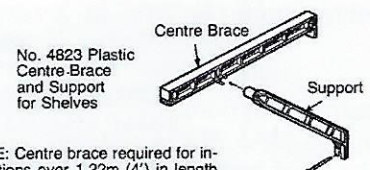
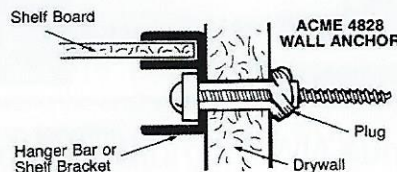

NOTE: Centre brace required for installations over 1.22m (4') in length and one for each additional 1.22m (4').

ALSO AVAILABLE IN 16" (40.64cm) DEPTH